

HELI

Reliable special designed instrument

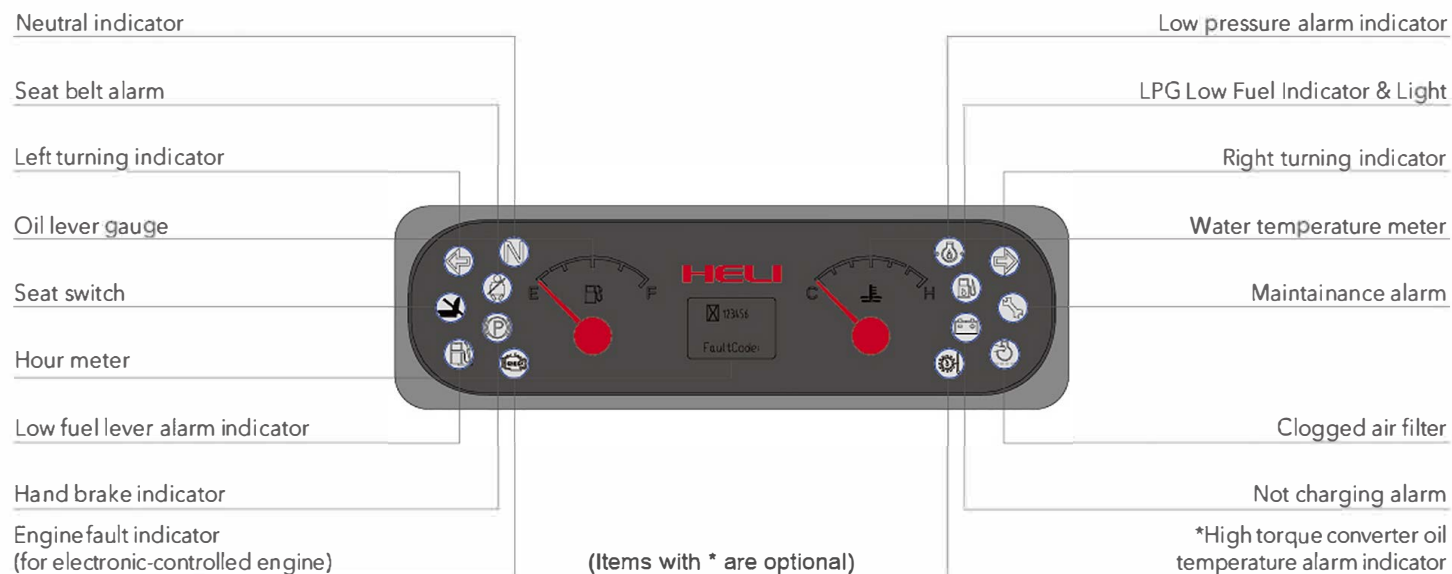

Standard configuration Optional

Hom	Standard fork	Driver's cab	Double-tyre and protected device
Control valve	Integration electric box	Warning light	Rotating seat for LPG
Wholly hydraulic-powered steering	Hydraulic circuit oil filter	High air exhausting device	Over speed alarm
Half surrounded seat	Speed-limiting valve	Double air cleaner	Counter weight protective screening
Backrest	Wide view mast	Suspension seat	Rear View Camera/Overhead guard top rain glass
Rear view mirror	Air intake device	Fork extension	SAE standard
Front combined lamp	Durable tire with decorative pattern	Heater	Engine hood locking
Transmission oil filter	Lifting and tilting operation handles	Solid tyre	Thin-point type fork
Engien flame out device	Traction pin	Widen fork carriage	Soundproof and noise reducing device
Ratchet type parking brake	Head lamp	Wind shield	Universal key
Driver's tools	Hydraulic oil dipstick	Rear working light	Radiator protected screening
Power brake	Overhead guard	Air condition (certain type)	Tractor pin with mild steel safeguard
Rear combined lamp	Torque converter oil dipstick	Torque converter oil temperature meter	Overspeed alarm device
Reversing buzzer	Combined instrument	Tilting cylinder protection cover	High temperature resistant device
Tilt-lock valve	Electric-hydraulic direction changing	User-specified color	Fuel tank with lock
Tilt adjustable steering column		Optional attachments	Weighting device
Overhear guard rain cover			Cab with skylight
OPS(travling control system)			

HELI
LIFTING THE FUTURE

heliforklifts.co.nz
Contact us direct or get in touch with your local dealer
0800 435 469
sales@heliforklifts.co.nz

Catalog No.201912 Forklift Print

HELI

4-5 t

H3 series Internal Combustion Counterbalanced Forklift Truck



heliforklifts.co.nz

H3 SERIES 4-5 t

Technical features remarkably improved



Damping

> With suspension damping struction on overhead guard and optimized design for the transmission,the whole trucks's vibration reduced a lot and relieve driver's fatigue greatly

Noise reduction

> Equipped with optimize designed parts around the engine,noise nearby ear and the truck sound level are reduced greatly

Heat dissipation

> With the optimized cooling system and great cooling performance,highly improved the reliability and durability of the transmission and engine,etc, many key parts.



Efficiency

> With more power and low emission engine,stronger loading capacity,higher gradeability;With load sensing hydraulic system,quicker lifting speed,higher working efficiency

Reliability

> Strengthen and Optimize designed core structure parts,strength improved greatly;with intelligent gear shifting technology to avoid 2nd-gear start,improved transmission life

Comfort

> Intelligent gear shifting system,ease of operation Standard half surrounded seat,safety and comfort

Maintainability

> Wider internal space,more reasonable parts layout and 80°hood opening angle make maintenance easy

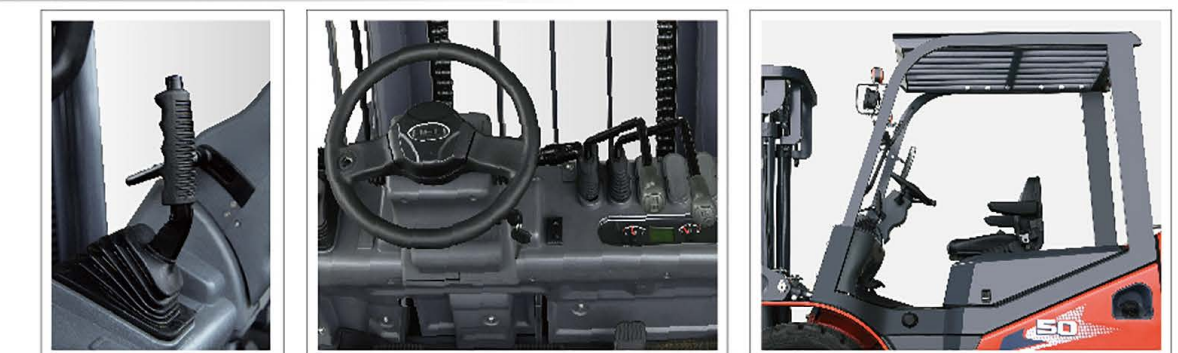

Manufacturer and technical parameters						
Character						
1.01	manufacturer				HELI	
1.02	model		CP (Q) YD40		CP (Q) YD45	CP (Q) YD50
1.03	rated capacity		kg	4000	4500	5000
1.04	load center		mm		500	500
1.05	operation mode		type		Seat-type	
Dimensions						
2.01	Max.lifting height	H	mm	3000	3000	3000
2.02	Mast overall height(fork to the ground and mast be vertical)	H1	mm	2275	2275	2275
2.03	Max.fork lifting height(with backrest)	H2	mm	4250	4250	4250
2.04	Free lift height	H3	mm	150	150	150
2.05	Overall height(overhead guard)	H4	mm	2350	2350	2350
2.06	Min.ground clearance(at the mast)	H5	mm	175	175	175
2.07	Distance from the surface of the seat to the overhead guard	H6	mm	1020	1020	1020
2.08	Traction pin height	H9	mm	380	380	380
2.09	Backrest height(calculated from the surface of the fork)	H13	mm	1250	1250	1250
2.10	Overall length(with fork/without fork)	(L/L')	mm	4310/3240	4310/3240	4460/3240
2.11	Wheel base	L1	mm	2100	2100	2100
2.12	Front overhang	L2	mm	560	560	560
2.13	Rear overhang	L3	mm	580	580	580
2.14	Overall width	W1	mm	1510	1510	1510
2.15	Tread (front/rear)	(W3/W2)	mm	1230/1190	1230/1190	1230/1190
2.16	Fork adjustable range(the external of the fork)(Max./Min.)	W5	mm	1330/300	1330/300	1330/300
2.17	Min.turning radius(exterior)	r	mm	2860	2860	2860
2.18	Min.turning radius(interior)	r'	mm	215	215	215
2.19	Min.rightangle aisle width	Ra	mm	2820	2820	2820
2.20	Min.rightangle stacking aisle width	Ast	mm	4760	4760	4760
2.21	Masttilting angle (front/rear)	α/β	deg	6°/12°	6°/12°	6°/12°
2.22	Fork size	L4×W×T	mm	1070×150×50	1070×150×50	1220×150×50
Weight						
3.01	Total weight		kg	6540	6740	7000
Wheel and tyre						
4.01	Wheel number x = drive wheel (front/rear)				2X/2	
4.02	Tyre type(front/rear)				Pneumatic tyre	
4.03	Tyre size(front/rear)			8.25-15-14PR/7.00-12-12PR	300-15-18PR/7.00-12-12PR	
4.04	Service brake				Hydraulic-Foot Pedal	
4.05	Parking brake				Mechanical-Hand Lever	

Performance							
Model		CPQYD40-KUH	CPQYD45-KUH	CPQYD50-KUH	CPYD40-KUH	CPYD45-KUH	CPYD50-KUH
Max.drawbarpull (Loaded/Unloaded)	kN	35/25	35/25	36/25	37/23	37/23	38/23
Max.Gradeability (Loaded/Unloaded)	%	30/21	29/21	27/21	30/21	29/21	27/21
Max.traveling speed (Loaded/Unloaded)	km/h	26/27					
Lifting Speed (Loaded/Unloaded)	mm/s	580/600					
Lowing Speed (Loaded/Unloaded)	mm/s	420/440					
Drive and transmission control device							
Engine mode		KUBOTA WG3800					
Engine rated power	kW/rpm	GAS:54.6/2400 LPG:54.6/2400			LPG:63.2/2400		
Engine rated torque	Nm/rpm	GAS:246.8/1400 LPG:271.4/1400			LPG:282.4/1200		
Engine cylinder number-bore x stroke		4-100×120					
piston displacement	L	3.77					
Engine type		GAS/LPG			LPG		
Engine Emissions		EPA/CARB,EUstage V					
Battery(Voltage/Capacity)	V/Ah	12/80					
Engine fuel tank capacity	L	90					
Transmission box shifting gears(front/rear type)		2-1Power Shift T/M					

Note: *stands for theoretical calculating value.

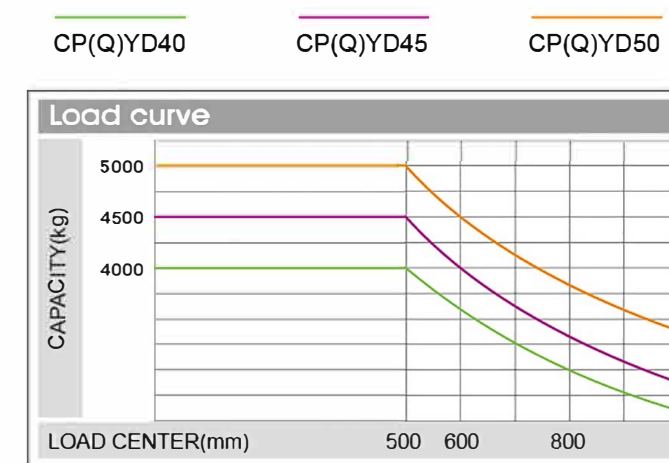
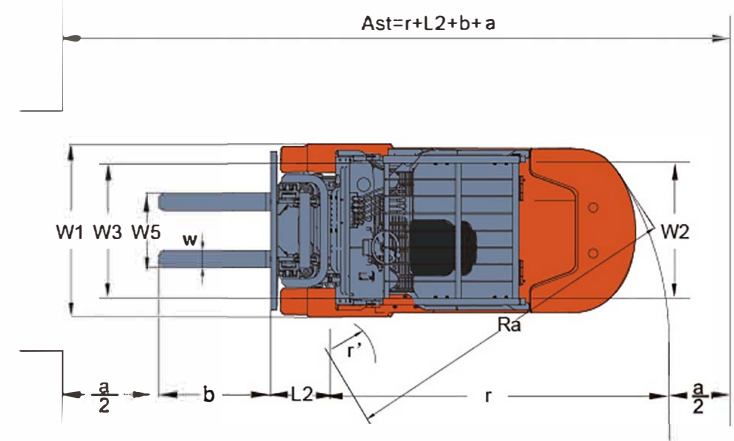
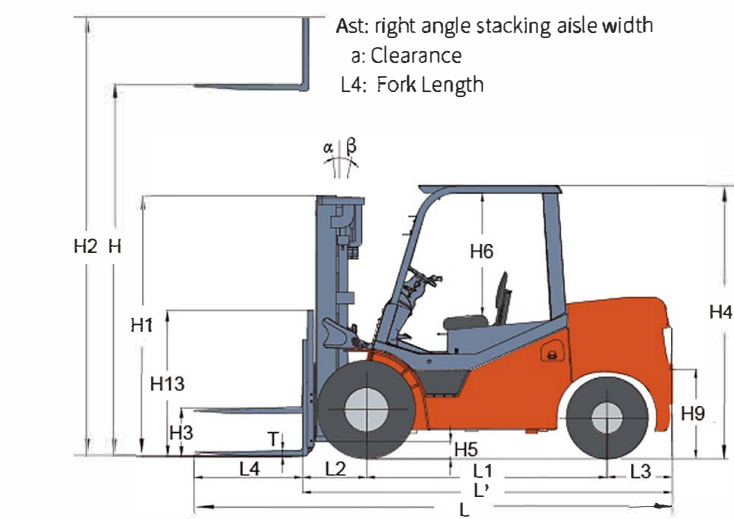

Note: The vertical axis stands for load capacity and the horizontal axis stands for load center which is calculated from the front of the fork. The base point of the standard load refers to the center position of the cube with 1000mm length of side. When mast is tilted forward, nonstandard fork usage or load with over wide goods, load capacity will be reduced. Different load capacity in different load center can be known in time through load chart.

WIDE VIEW MAST										
Mast model	Max. lifting height mm	Load capacity (load center 500mm) Kg			Overall Height (fork to the ground) (mm)	Free lift height (With Backrest) (mm)	Service Weight(unload)Kg			Mast tilting angle (°) α/β
		CP(Q)YD40	CP(Q)YD45	CP(Q)YD50			CP(Q)YD40	CP(Q)YD45	CP(Q)YD50	
M260	2600	4000	4500	5000	2075	150	6510	6710	6970	6°/12°
M270	2700	4000	4500	5000	2125	150	6520	6720	6980	6°/12°
M300	3000	4000	4500	5000	2275	150	6540	6740	7000	6°/12°
M330	3300	4000	4500	5000	2425	150	6560	6760	7020	6°/12°
M350	3500	4000	4500	5000	2525	150	6580	6780	7040	6°/12°
M370	3700	4000	4500	5000	2625	150	6590	6790	7050	6°/12°
M375	3750	4000	4500	5000	2650	150	6600	6800	7060	6°/12°
M400	4000	4000	4500	5000	2825	150	6610	6810	7070	6°/6°
M425	4250	4000	4500	5000	2950	150	6670	6870	7130	6°/6°
M450	4500	4000	4500	5000	3075	150	6680	6880	7140	6°/6°
M475	4750	4000	4500	5000	3200	150	6700	6900	7160	6°/6°
M500	5000	4000	4500	5000	3325	150	6720	6920	7180	6°/6°
M550	5500	4000	4500	5000	3575	150	6730	6930	7190	3°/6°
M600	6000	4000	4500	5000	3825	150	6750	6950	7210	3°/6°

Note: (1) *stands for the rated capacity when the front tyre is double-tyre.
(2) When the front tyre of the 2-3.5t truck is double tyre, the service weight of the truck is the weight in the table plus 110kg.

WIDE VIEW FULL FREE 2-STAGE MAST										
Mast model	Max. lifting height mm	Load capacity (load center 500mm) Kg			Overall Height (fork to the ground) (mm)	Free lift height (With Backrest) (mm)	Service Weight(unload)Kg			Mast tilting angle (°) α/β
		CP(Q)YD40	CP(Q)YD45	CP(Q)YD50			CP(Q)YD40	CP(Q)YD45	CP(Q)YD50	
ZM261	2610	4000	4500	5000	2110	530	6615	6815	7075	6°/12°
ZM271	2710	4000	4500	5000	2160	580	6640	6840	7100	6°/12°
ZM300	3000	4000	4500	5000	2305	725	6690	6890	7150	6°/12°
ZM330	3300	4000	4500	5000	2455	875	6705	6905	7165	6°/12°
ZM350	3500	4000	4500	5000	2555	975	6715	6915	7175	6°/12°
ZM375	3750	4000	4500	5000	2680	1100	6730	6930	7190	6°/12°
ZM400	4000	4000	4500	5000	2805	1225	6745	6945	7205	6°/6°
ZM450	4500	4000	4500	5000	3055	1475	6770	6970	7230	6°/6°
ZM500	5000	4000	4500	5000	3305	1725	6805	7005	7265	6°/6°
ZM550	5500	4000	4500	5000	3555	1975	6830	7030	7290	3°/6°
ZM600	6000	4000	4500	5000	3805	2225	6855	7055	7315	3°/6°

Note: (1) *stands for the rated capacity when the front tyre is double-tyre
(2) When the front tyre of the 8000-10000lbs truck is double tyre, the service weight of the truck is the weight in the table plus 300lbs
(3) The free lifting height (without backrest) of the 8000-10000lbs truck is the height (without backrest) in the table plus 325mm

WIDE VIEW FULL FREE 3-STAGE MAST										
Mast model	Max. lifting height mm	Load capacity (load center 500mm) Kg			Overall Height (fork to the ground) (mm)	Free lift height (With Backrest) (mm)	Service Weight(unload)Kg			Mast tilting angle (°) α/β
		CP(Q)YD40	CP(Q)YD45	CP(Q)YD50			CP(Q)YD40	CP(Q)YD45	CP(Q)YD50	
ZSM392	3920	4000	4500	5000	2250	650	6880	7080	7340	6°/6°
ZSM435	4350	4000	4500	5000	2395	795	6900	7100	7360	6°/6°
ZSM450	4500	4000	4500	5000	2445	845	6920	7120	7380	6°/6°
ZSM470	4700	4000	4500	5000	2515	895	6940	7140	7400	6°/6°
ZSM480	4800	4000	4500	5000	2545	990	6950	7150	7410	6°/6°
ZSM500	5000	4000	4500	5000	2645	1040	6970	7170	7430	6°/6°
ZSM540	5400	4000	4500	5000	2760	1165	7010	7210	7470	6°/6°
ZSM600	6000	4000	4500	5000	3010	1405	7090	7290	7550	3°/6°

Note: (1) *stands for the rated capacity when the front tyre is double-tyre
(2) When the front tyre of the 8000-10000lbs truck is double tyre, the service weight of the truck is the weight in the table plus 300lbs
(3) The free lifting height (without backrest) of the 8000-10000lbs truck is the height (without backrest) in the table plus 325mm