

Manufacturer's Data and Design Characteristics									
Characteristics									
1.01	Manufacturer	<b>HELI</b>							
1.02	Model	CBD15J-Li3	CBD18J-Li3		CBD20J-Li3				
1.03	Power unit	Electric			Electric		Electric		
1.04	Operation	Pedestrian			Pedestrian		Pedestrian		
1.05	Rated traction weight	Q (t)	1.5	1.8	2.0				
1.06	Load centre	c (mm)	600	600	600				
1.07	Axle centre to fork face	x (mm)	944	944	944				
1.08	Wheelbase	y (mm)	1190	1190	1190				
Weights									
2.01	Service weight with battery	kg	138	148	150				
Wheels/Tyres									
3.01	Wheels type	Polyurethane			Polyurethane		Polyurethane		
3.02	Driving wheel size	Φ×w (mm)	Φ210×70	Φ210×70	Φ210×70				
3.03	Bearing wheel size	Φ×w (mm)	Φ80×60	Φ80×60	Φ80×60				
3.04	Wheels, number front/rear (x = driven)	1x/4			1x/4		1x/4		
3.05	Track width	b11 (mm)	400/535	400/535	400/535				
Dimensions									
4.01	Lift	h3 (mm)	200	200	200				
4.02	Overall height(With handle)	h14 (mm)	725/1145	725/1145	725/1145				
4.03	Lowered height	h13 (mm)	65	65	65				
4.04	Overall length	l1 (mm)	1550	1550	1550				
4.05	Length to fork face	l2 (mm)	400	400	400				
4.06	Overall width	b1/ b2 (mm)	550/685	550/685	550/685				
4.07	Fork dimensions	s/e/l (mm)	50/150/1150	50/150/1150	50/150/1150				
4.08	Width of forks	b5 (mm)	550/685	550/685	550/685				
4.09	Min.Ground clearance	m2 (mm)	35	35	35				
4.10	Aisle width with pallet 1000 x 1200 across forks	Ast (mm)	1750	1750	1750				
4.11	Aisle width with pallet 800 x 1200 along forks	Ast (mm)	1800	1800	1800				
4.12	Min.Turning radius	Wa (mm)	1345	1345	1345				
Performance									
5.01	Travel speed,laden/unladen	(km/h)	4.2/4.5	4.2/4.5	4.2/4.5				
5.02	Maximum climbing ability, with/without load	(%)	5/10	5/10	5/10				
5.03	Service brake	Electromagnetic brake			Electromagnetic brake		Electromagnetic brake		
Drive									
6.01	Drive motor, 60 minute rating	(kW)	0.75	0.75	0.75				
6.02	Lift motor rating at S315%	(kW)	0.8	0.8	0.8				
6.03	Battery according to DIN 43531/35/36 A,B,C,no	no			no		no		
6.04	Battery voltage/rated capacity	(V/Ah)	24/20	24/30	24/40	48/15	48/20	48/15	48/20
6.05	Battery weight (± 5%)	(kg)	5.5	7	8.2	7	8.2	7	8.2
Others									
7.01	Type of drive control	DC			DC		DC		
7.02	Noise level at operator's ear	(dB(A))	≤ 70	≤ 70	≤ 70				
7.03	Steering type	Mechanical steering			Mechanical steering		Mechanical steering		
7.04	Controller brand	Curtis			Curtis		Curtis		

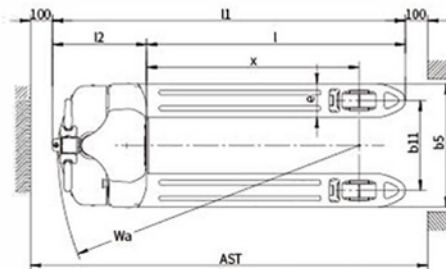

# CBD15J/18J/20J-Li3

## The 3rd Generation Lithium Battery Pallet Truck

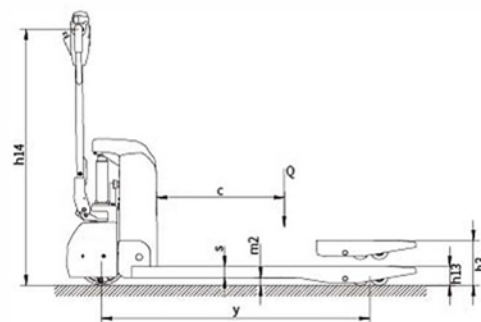

# 1 EASY TO MAINTENANCE



**Lithium battery, maintenance free**



**Brushless drive motor, maintenance free**



**5s Replace Battery**



**Error code display**



**Perfect after-sales and accessory services**



**Built-out charger is standard**

# 2 PERFORMANCE



- − UNLADEN 4.5Km/h
- + LADEN 4.2Km/h

## Gradeability

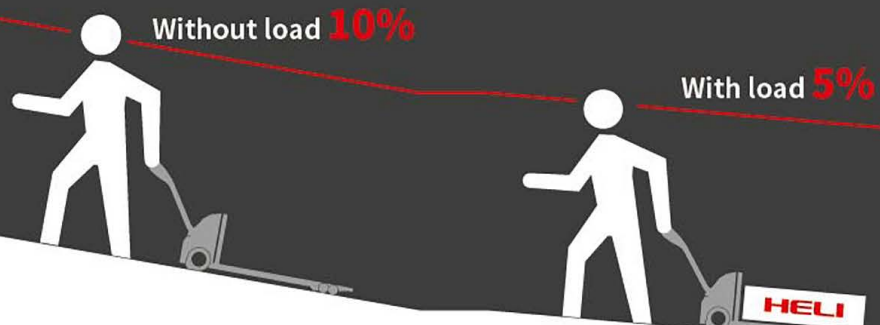

# 3 CHARACTERISTICS

closer look into



Built-in Charger (Optional)



Built-out Charger



Concave Design



Integral Forks



PU Wheel



Smart Handle (Optional)



Normal Handle



Battery Protection Stopper



Electric Lifting/Lowering



Protection Cover

