

CDD13J-ZK-S Electric pallet stacker

Load Curve

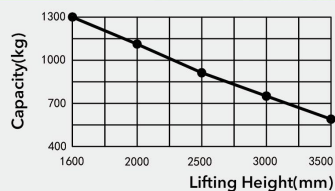

Characteristics:

- High strength mast.
- Permanent magnet motor drive system.
- German water-proof switch
- Built-out charger.
- Integrated operating handle
- Four-color LED power meter displays.
- Operating handle with gas spring.
- Turtle speed switch.
- Double up and down buttons.
- High power lift pump.
- Extended operating handle.
- Side driving, smaller steering radius.
- Adjustable wide leg design.



CDD13J-ZK-S

Manufacturer's Data and Design Characteristics

Characteristics							
1.01	Manufacturer	HELI					
1.02	Model	CDD13J-ZK-S					
1.03	Operation	Walkie					
1.04	Rated traction weight	Q(kg)	1300				
1.05	Mast type		Single mast	2-Stage mast			
1.06	Lift	h3(mm)	1600	2000	2500	3000	3500
1.07	Capacity at highest height	kg	1300	1300	1300	900	600
1.08	Service weight(include battery)	kg	618	634	646	658	670
1.09	Load center	c(mm)	600				
1.10	Alxe centre to fork face	x(mm)	698				
1.11	Wheel base	y(mm)	1202				
1.12	Controller	CURTIS					
Wheel/Tyres							
2.01	Wheel type	Φ×w(mm)	Polyurethane				
2.02	Driving wheel size	Φ×w(mm)	Φ210×70				
2.03	Bearing wheel size	Φ×w(mm)	Φ80×70				
2.04	Wheel,number front/rear(X=drive)		1x+0/4				
Dimensions							
3.01	Height of mast, lowered	h1(mm)	2099	1580	1830	2080	2330
3.02	Height of mast, extended	h4(mm)	2099	2549	3049	3549	4049
3.03	Fork Height,Lowered	h13(mm)	65				
3.04	Overall length	l1(mm)	1818				
3.05	Length to fork face	l2(mm)	668				
3.06	Overall width	b1/b2(mm)	1148-1548				
3.07	Fork dimension	s/e/(mm)	35/100/1150				
3.08	Width of forks	b5(mm)	210-850				
3.09	Min.Ground clearance	m2(mm)	26				
3.10	Aisle width with pallet 1000*1200 across forks	Ast(mm)	2240				
3.11	Aisle width with pallet 1000*1200 along forks	Ast(mm)	2210				
3.12	Min.Turning radius	Wa(mm)	1370				
Performance							
4.01	Travel speed,with/without load	(km/h)	4.0/4.2				
4.02	Lifting speed,with/without load	(mm/s)	92/136				
4.03	Lowering speed,with/without load	(mm/s)	112/98				
4.04	Max.gradeability,laden/unladen	(%)	3/8				
4.05	Service brake		Electromagnetic brake				
Drive							
5.01	Drive motor,output S2 60 min	(kw)	0.75				
5.02	Lift motor rating at S3 15%	(kw)	2.2				
5.03	Battery according to DIN 43531/35/36 A,B,C,no		no				
5.04	Battery voltage/rated capacity	(V/Ah)	2×12/100				
5.05	Battery weight(± 5%)	(kg)	2×27				
Others							
6.01	Noise level at operator's ears	(dB(A))	≤70				
6.02	Steering type		Mechanical steering				

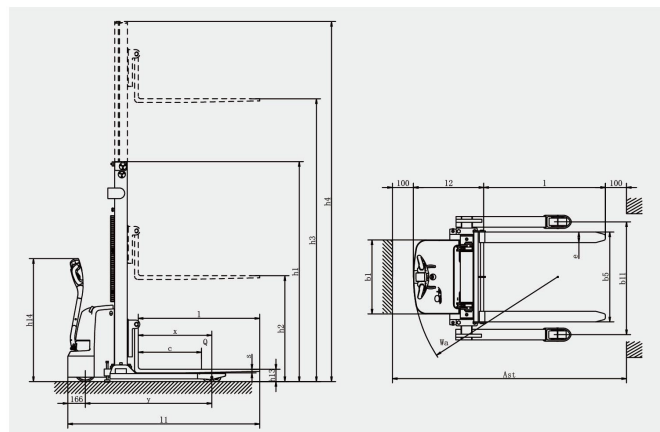

* Our products are subject to improvements and changes without notice.



ANHUI HELI CO., LTD.

Add / No.668, FangXing Road, Hefei, China
Fax / +86-551-63639966

Tel / +86-551-63639068(America);
63639258(Europe); 63639358(Asia);
63662105(Africa & Middle East);
63639530(Key Accounts Division);
63662105(Wheel loader)