

HELI

45t

REACH STACKER



REACH
STACKER



1996 and its registered capital is 616.8 million. It is presently an industrial vehicle research and development, manufacturing and export base in China with large scale, complete product line and industrial chain and strong overall strength.



A. High design standard

- Truck performance is ensured with accurate theoretic data as design basis through CAE analysis, finite element analysis, modal analysis and dynamics simulated analysis on key parts like frame, telescopic boom and so on and full digitalized 3D software during truck development. The design scheme of the completed truck is mature and reliable and achieves same performance level as the same product in European market. Not only China design standard GB/T26474-2011 is satisfied, EN1459 and ISO 15018 design standards are also satisfied.



European Alliance
CE Certificate
欧盟CE认证



B. Complete series

- Heli co-develops reach stacker with EURO famous port machinery design company for handling and stacking 20 foot and 40 foot fully loaded container. It is widely used in port, dock, railway system, container terminal and so on. Heli reach stacker has the characteristics of complete series, reliable safety performance, good energy saving and environmental protection performance and high working efficiency. The truck is assembled with electric controlled overload protection system, automatic fire extinguishing system, backward integrated monitoring system and so on. The truck has world advanced performances and it is worth to choice.



C. Reliable quality

- **Electric controlled overload protection system**

Intelligent overload protection system can automatically detect axle steering angle and adjust spreader state to ensure lifting within safety range. And thus working safety and working efficiency is largely improved.

- **Backward Integrated monitoring system**

Backward Integrated monitoring system can monitor the safety around the truck at any time to ensure truck safety driving.

- **Truck fire extinguishing control system (Optional)**

Powerful automatic fire extinguishing system is installed in the key position of the truck achieving fire pre-alarm, antilflaming and fire extinguishing functions. It is safe and reliable.

- **Vacuum pneumatic tyre**

Vacuum pneumatic tyre with good buffering function reduces shock contact between truck and ground. It is safer and more comfortable. What is more, maintenance cost is largely reduced and structural parts service life is largely increased.



- **Reliable power system**

Imported VOLVO/CUMMINS engine with original packing is assembled on the truck. It is powerful and reliable. Combined with advanced power matching technology and control technology, truck performance is brought into better play.



- **Reliable structure design**

Truck performance is ensured with accurate theoretic data as design basis through CAE analysis, finite element analysis, modal analysis and dynamics simulated analysis on key parts like frame, telescopic boom and so on and full digitalized 3D software during truck development. The design scheme of the completed truck is mature and reliable and achieves same performance level as the same product in European market. Not only China design standard GB/T26474-2011 is satisfied, EN1459 and ISO 15018 design standards are also satisfied.



D. High efficient working



- ◆ **Energy regenerating technology**

Big arm oil cylinder overall process "energy regenerating" automatic controlling function uses the return oil in the cylinder upper cavity for lifting and thus offers faster lifting speed and higher efficiency.

- ◆ **Vertical lift function**

Big arm stretching out and drawing back function and lifting and lowering function can be realized simultaneously with combined type "vertical lift" automatic control function. And thus working efficiency is improved.

- **Comfort operation environment**

Through convenient man-machine interactive operation interface, operator can control truck real time working state. Wide view and fully suspension adjustable seat improve operator comfort, reduce operation fatigue and increase working efficiency largely.

- **Container stacking statistics and print system (optional)**
Official configuration improves daily working management efficiency.



E. Low cost

- **Energy saving power system**
Suitable power system matching can automatically identify dynamic power according to the change of load, adjust engine speed and bring truck high working efficiency and low oil consumption performance into full play.



- **Hydraulic load sensing system**

Hydraulic load sensing system can adjust oil pump output flow according to actual load and achieve high precision control on flow. And thus engine load is reduced and truck oil consumption is reduced.

- **Vacuum pneumatic tyre**

Vacuum pneumatic tyre with good buffering function reduces shock contact between truck and ground. It is safer and more comfortable. What is more, maintenance cost is largely reduced and structural parts service life is largely increased.

- **LED lighting system**

LED lighting system which is bright and has low energy consumption offers better lighting for working and indication.



F. Easy maintenance



- **Fully surrounded anti-skidding getting on and off safety passway**

You can reach to the area needs repair safely and quickly through fully surrounded anti-skidding getting on and off safety passway and thus repair is more convenient.

- **Outside Installed maintenance and repair check mechanism**

Outside installed fuel filter, hydraulic oil filter and filter core facilitate daily maintenance, shorten maintenance time and improve truck maintenance efficiency.

- **Centralized lubricating system**

Centralized lubricating system makes maintenance easy and extends parts service life.

- **Worldwide spare parts store centers**

No matter where you are, HELI local sales network or dealers can provide you with spare parts locally or directly from HELI headquarters quickly.



G. Spreader



- 817 type spreader from world famous spreader manufacturer——Sweden ELME is assembled on the truck. The spreader is designed for reach stacker. The spreader is made by high-quality steel and it has single-cylinder type structure, high strength and good view.

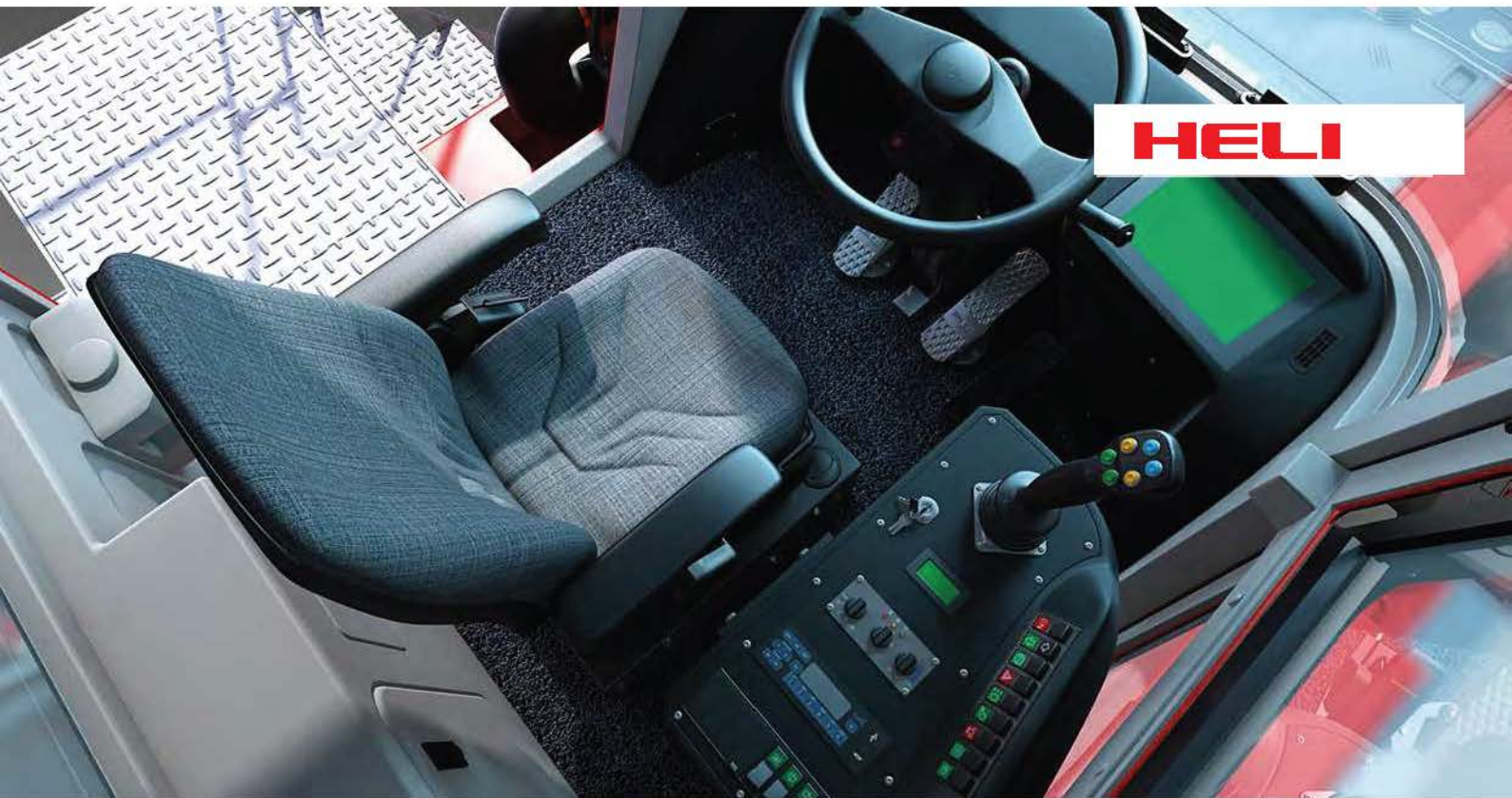

HELI

H. Improved driver's cab

- Newly designed cab is standard configuration of the reach stacker. Oversized cambered glass on the cab offers wide view.



- The buttons' layout on panel satisfies ergonomics requirements and ensures comfort operation space.



- Through convenient and beautiful man-machine interactive operation interface, operator can control truck real time working state.



- Fully suspended adjustable seat largely improves operator comfort, reduces operation fatigue and improves working efficiency.
- Fully enclosed design improves sound insulation and vibration proof performance and noise inside of the cab is reduced to 70dB.
- Fire extinguisher is equipped in the cab to ensure safety.



Load diagram

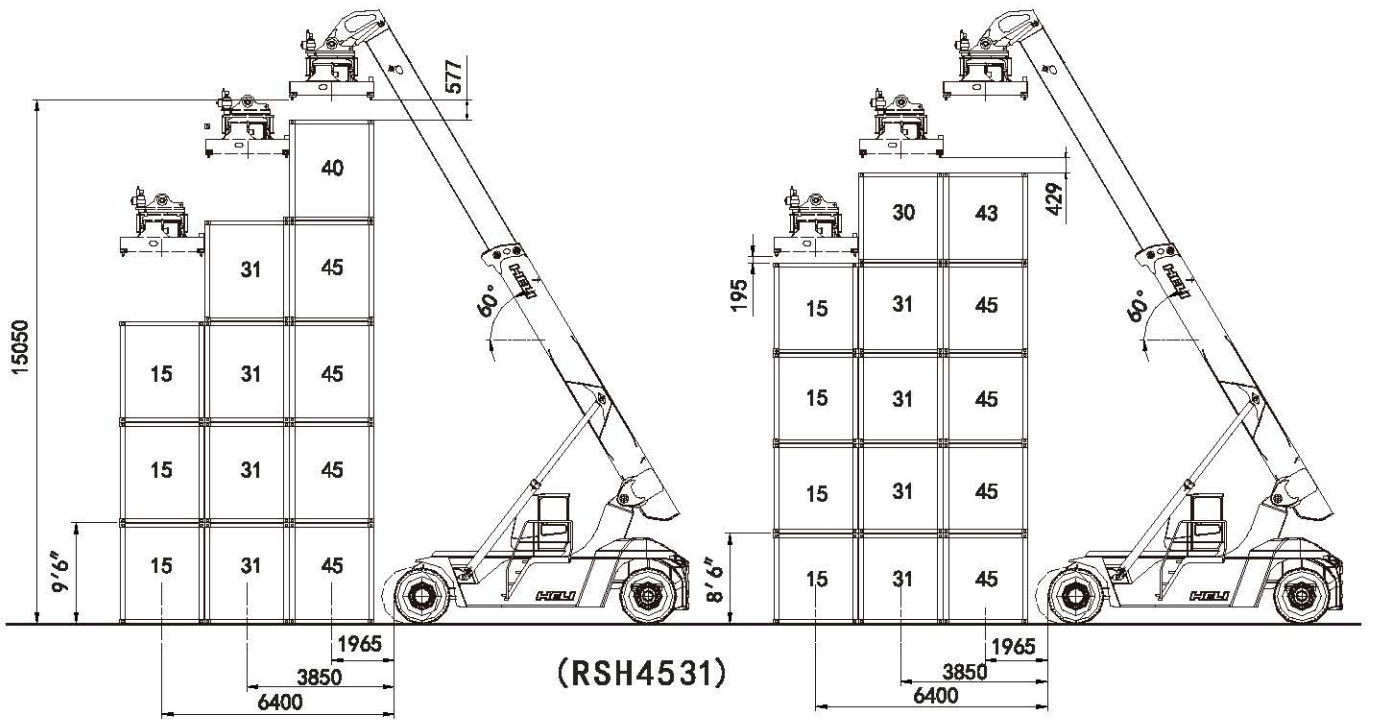
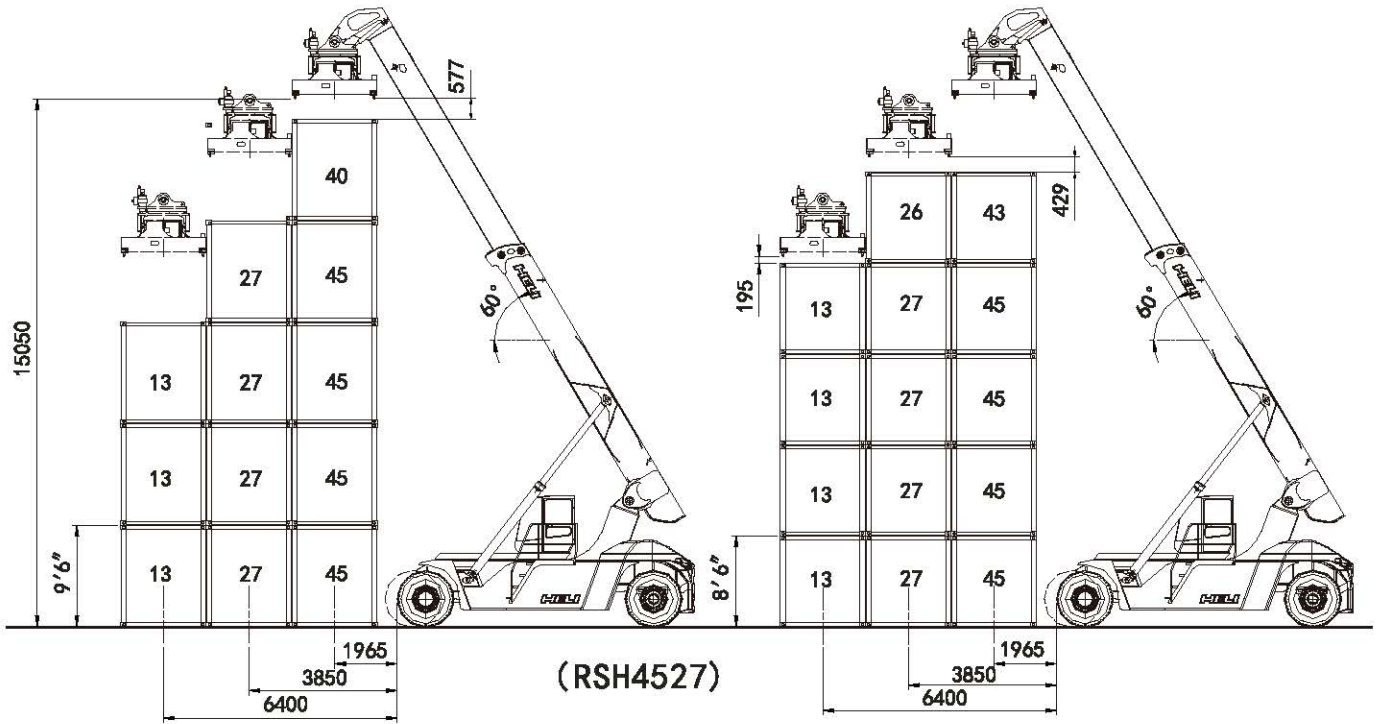

Performance specifications

Model			RSH4527-VO3/VO4/VO5	RSH4531-VO3/VO4/VO5
Lifting capacity	First row/second row /third row	Kg	45000/27000/13000	45000/31000/15000
Load center	First row/second row /third row	mm	1965/3850/6400	1965/3850/6400
Max. lifting height (first row)		mm	15050	15050
Container Spreader	Side shift	mm	± 800	± 800
	Rotation	deg	-105~+195	-105~+195
Min. turning radius		mm	7990	7990
Spreader max. tilting angle		deg	60	60
Wheel base		mm	6000	6000
Tread (front/rear)		mm	3030/2838	3030/2838
Length		mm	11300	11300
Width		mm	4148	4148
Height		mm	4754	4754
Tyre	Specification		18.00-25-40PR	18.00-25-40PR
	(Front/rear)		4/2	4/2
Engine	Model		Volvo TAD1151	Volvo TAD1151
	Rated output/Speed	kW/rpm	265/2100	265/2100
	Rated torque/Speed	Nm/rpm	1785/1316	1785/1316
	Emissions standards		欧三/国三	欧三/国三
Transmission box (front/rear)			DANA 36000/TE27	DANA 36000/TE27
Drive axle			Kessler	Kessler

Formal Size

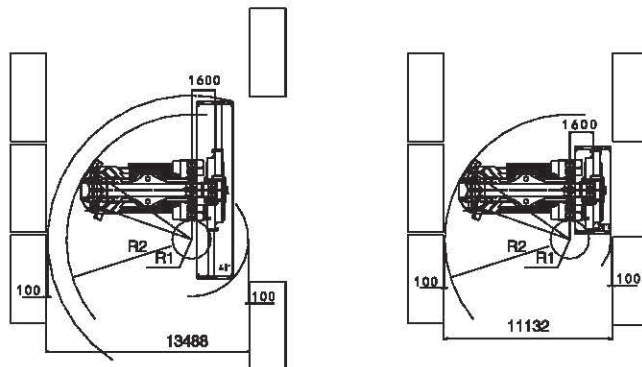
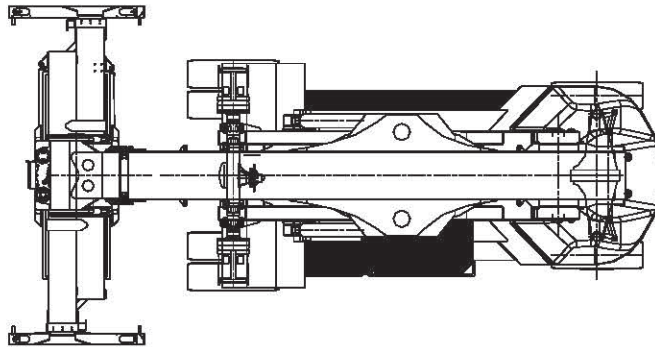
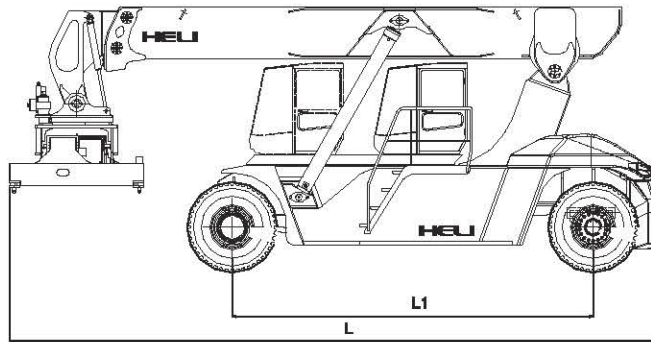
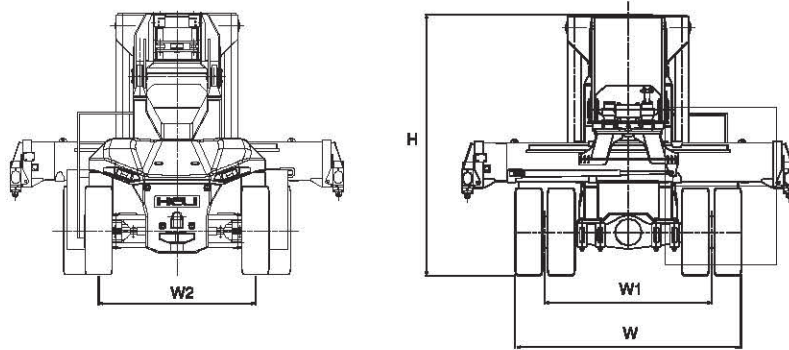

直角通道宽度

REACH
STACKER



Optional		
No.	Item	Note
1	container stacking statistics and print system	Miniprinter: it can print container weight, number and hoisting container quantity.
2	Automatic fire extinguishing system	Heat sensitive dry powder extinguisher can extinguish automatically and it is safe and efficient.
3	Imported vacuum tyre	Tyre choice can be customized and imported vacuum tyre is optional.
4	Automatic lubricating system	Lubricating pump is assembled on the truck to add lubricating grease on time with proper quantity to ensure fully lubrication of key parts and extend replace period.
5	Container weighting system	Accurate container weighting system meets relative industry' s requirement and provide better safe protection.
6	Automatic lock when slings catching container	Sling will be locked automatically when catching container. Driving comfort and working efficiency are improved

HELI smart fleet management system

- Vehicle positioning
- Remote diagnosis
- Remote monitoring
- Maintenance reminder
- Statistical form
- Vehicle management
- Identification recognition (optional)
- Weight management (optional)





J. Professional service

- HELI provides customers with close technical support, training and service before sales, during sales and after sales adhering to the cooperation value of "Good faith cooperation and altogether wins development" . Our object is to reach long term cooperation relationship with customers.
- Correct maintenance and operation is an important precondition to ensure truck service life and reduce truck downtime. We will provide perfect and professional technical support to ensure truck high efficient working.



- **Worldwide spare parts store centers**
No matter where you are, HELI local sales network or dealers can provide you with spare parts locally or directly from HELI headquarters quickly.
- **Worldwide service network**
As China advanced forklift truck manufacturer, HELI sales network and dealer all over the world meet customers' need with sincere service.
- **Customer service**
“Customer first” is our market value. Customers can receive sincere service from HELI network or dealers who will provide fast, flexible and professional service.
- **Technical support to satisfy your need**
We can provide professional service when you need. Through our worldwide network or dealers or headquarter, we can satisfy your need through our technical experts or technicians with rich experience.
- **Training**
Through our worldwide network or dealers, we will provide you with customized professional driving and repair trainings according to different truck models.

REACH
STACKER

HELI
LIFTING THE FUTURE



heliforklifts.co.nz

Contact us direct or get in touch with your local dealer

0800 435 469
sales@heliforklifts.co.nz